

PAPER TIGER CLASS ASSOCIATION

BY-LAW 1.

CLASS RULES

1-GENERAL

The **PAPER TIGER** catamaran is a one-design class. Boats shall conform to the general requirements and outlines shown on the plans except as modified by these Class Rules.

In accordance with the ISAF Equipment Rules of Sailing, these Class Rules fall under the definition of clause C.3.2 "Open Class Rules" which state:

"**Class rules** where anything not specifically prohibited by the class rules is permitted"

Interpretation or clarification of the Class Rules shall be requested in writing from the International Measurers.

Boats that do not comply with the Class Rules shall be liable for disqualification from class events, in accordance with the ISAF Yacht Racing Rules.

For the purpose of measurement, should the class rules be silent on a measurement matter (including measurement procedure), the ISAF measurement procedures shall apply.

NOTE: Details of fittings and method of construction on the plans are typical only. Alternate fittings (eg mast top pulley, mast base, mast spanner, traveller track, etc.) may be used providing they are not prohibited elsewhere in these Class Rules.

2-HULLS

1. Hulls may be made of any material.
2. Decks shall be straight in the athwartships direction. All hull panels to be flat in section profile allowing for natural twist in hull material between frame sections.
3. Hull length shall not exceed 4267mm excluding gunwales measured parallel with the designed waterline. This length shall be measured by drawing a straight line which transits the top of the main beam and a point 406mm above the keel at the transom.
4. Overall beam shall not exceed 2133mm excluding gunwales.
5. Gunwales (Rubbing Strakes or Sheerguard)
 - a) Gunwales may be made of any resilient material.
 - b) Gunwales shall be mounted externally.
 - c) Maximum dimensions: Width: 25mm, Height: 30mm.
 - d) Minimum dimensions: Width: 13mm, Height: 18mm.
 - e) Maximum width between main and rear beams: 40mm.
 - f) Width measurements are to be taken from the topsides of the hull.

- g) Minimum radius at the bow: 14mm in plan view.
 - h) The underside of the gunwale may be flat, convex, concave or tapered.
6. Hull measurements shall be in accordance with the plans and shall have a maximum tolerance of + or - 6mm on total width or depth. Maximum tolerance shall be + or - 12mm on bow profile. Maximum radius on keel and chine shall be 6mm except forward of station 2 on the chines.
 7. Measuring templates will be used at stations 2, 6, 10 and 14 and on bow profile.
 8. Hulls, which do not measure, may be given dispensation under the conditions set out in **BY-LAW 7**.

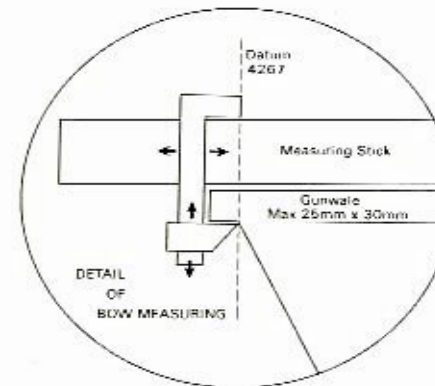
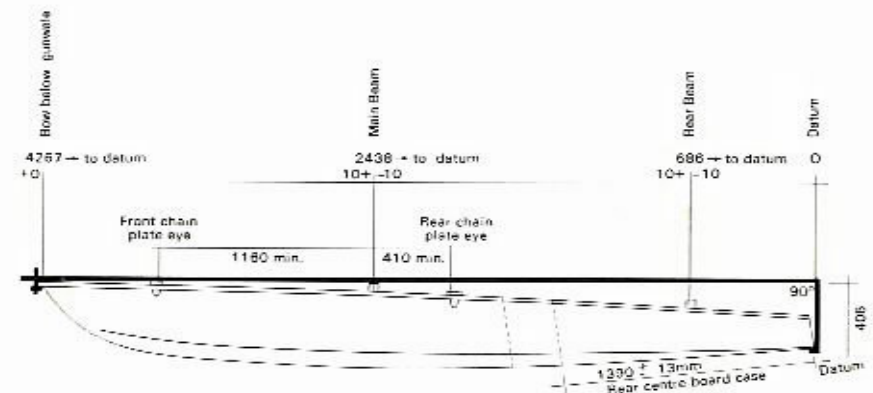

3-BEAMS AND TRAMPOLINE

1. Main and rear beams to be 50mm x 50mm + or - 1.0mm x 3.2mm + or - 0.3mm aluminium alloy square tube.
2. All beams must be mounted flush on the deck.
3. "L" brackets may be used to attach the beams at the inner attachment points of each hull only. Such "L" brackets shall have maximum dimensions of 50mm x 50mm x 50mm, and be constructed of aluminium alloy of a minimum of 4mm and maximum of 6mm in thickness.
4. Rear beam to be 686mm and main beam to be 2438mm each + or - 12mm to centrelines from transom at keel, measured parallel to waterline at deck level. Beam ends shall be angled at 45 degrees + or - 4 degrees.
5. A trampoline support of aluminium section shall be securely fixed along the centreline of the boat.
6. Trampoline material and attachment method to be optional.
7. Jumper strap shall be made from either stainless steel or aluminium alloy flat section and be within the following size limits.

	Minimum	Maximum
Stainless steel		
Width	25mm	50mm
Thick	3mm	4mm
Aluminium alloy		
Width	30mm	50mm
Thick	4mm	6mm

In addition to the above, aluminium alloy jumper straps shall have a minimum cross section of 160 square mm.

All sharp edges of jumper strap to be removed or protected (eg with electrical tape).

No part of the jumper strap shall extend beyond the inner gunwale.

8. Straight traveller tracks may be used instead of the hawse wire shown on the plans. Traveller length shall not exceed the length of the top surface of the rear beam.
9. Use of a single aluminium alloy extrusion that incorporates the rear beam, the traveller track, and a trampoline attachment track is permitted as long as it meets all other associated class rules.

4-WEIGHT

1. Minimum hull weight to be 50.0kg with all fixed fittings weighed in dry conditions excluding rudderstocks, mainsheet, but including inspection port covers and fixed compasses. Boats shall be EITHER weighed to one decimal place, OR the weight rounded to one decimal place.
2. For the purposes of weighing, each boat shall be freely suspended in a sling from an approved scale or spring balance.

3. Weighing of each end separately is not allowed.
4. Allowance shall be made for the weight of the slings.
5. Any weight required to bring a boat up to the minimum weight shall be fixed inside the ends of the beams as follows:
 - (a) Boats weighing more than 47.5kg - one half of weight in each end of main beam.
 - (b) Boats weighing 47.5kg or less - one quarter of weight in each end of main and rear beams.

5-CHAINPLATES

1. Chainplates must be positioned on the outer side of each hull.
2. No hole in the rear chainplate shall be within 410mm of the centreline of the main beam.
3. No hole in the front chainplate shall be within 1160mm of the centreline of the main beam.

6-CENTRECASES

1. Centrecases: rear of slot to be 1390mm + or - 15mm along the keel from outside of transom.
2. Maximum dimensions of centreboard slot measured at deck level shall be 25mm x 310mm and at keel level 25mm x 305mm. Recesses for centreboard stops are permitted providing they do not exceed 40mm in depth from deck level.
3. Centreboard must not be fitted with any device or means for angling centreboard to port or starboard.

7-CENTREBOARDS AND RUDDERS

1. No restriction on centreboards and rudders shall apply other than maximum centreboard dimensions as in rule 6(2) above.
2. The centreplane of each hull, its centreboard case and its rudderstocks (in the fore and aft position) shall coincide.
3. The maximum athwartships dimension of the rudder or rudderstock shall be 80mm within 100mm of the waterline projected from the transom.
4. The maximum distance from the transom to the centreline of the rudder pintle points shall be 70mm.

8-SPARS

1. Mast and boom shall be of a parallel aluminium alloy extrusion of minimum size 50mm x 64mm, maximum size 62mm x 80mm and minimum weight of 0.95kg/m. Tapering of mast extrusion is prohibited but internal stiffening is allowed.
2. Boltrope track must be continuous except for below the gooseneck and for boltrope entries. Separate boltrope tracks shall be considered part of the extrusion for measurement purposes.
3. Length of mast with top and bottom fittings not to exceed 6780mm from top of main beam to top of mast fitting.
4. Boom shall not exceed 2290mm in length including gooseneck plug.
5. Hounds attached to mast at 2590mm and 5180mm + or - 40mm measured from top of beam to shackle pin position. Shackle pin position shall be no greater than 25mm from the mast extrusion surface.
6. Mast must be sealed.
7. Boom block hangers - dimensions on plans are advisory only. There is no restriction on exact location, but block locations shall not be alterable while racing.
8. Downhaul control fittings shall be mounted on the mast and/or the spanner.
9. The boom vang shall be connected to one point only on the boom and shall be attached to a saddle or a spanner, attached at or near the base of the mast. The spanner may be designed to control mast rotation.
10. No connection other than those mentioned in 8 and 9 shall be made between the mast and the boom.
11. Devices to specifically control mast rotation other than the spanner and vang are prohibited.
12. Lever fittings to give greater boom vang purchase are permitted but must comply with items 9, 10 and 11 above.
13. Outhaul control fittings shall be located on or within the boom only.
14. The tails of control lines may be lead to positions of convenience and the slack taken up as long as the primary control load is taken by fittings positioned in accordance with the relevant class rule.

9-RIGGING

1. The rigging is to be in accordance with the plans except configuration of the lower forestays is optional. In addition, shackles and adjustable devices may be used to attach the stays/shrouds to the chainplates. Only the lower forestays may be adjusted while racing. Rigging dimensions quoted are advisory.

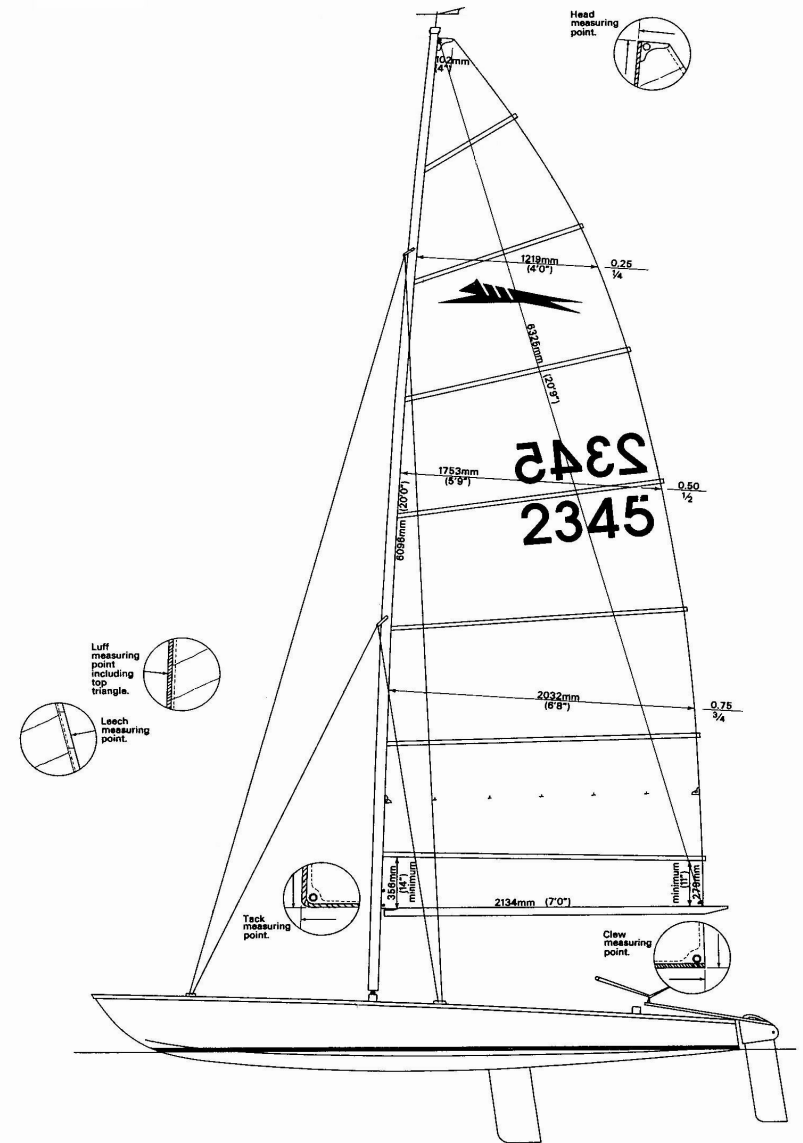

10-SAIL

1. To be measured in accordance with the ISAF measurement procedures, to meet the following restrictions and table of dimensions as represented by the drawing.

Note: Sail measurement dimensions and restrictions outlined herein supersede those on sheet five of the plans when in conflict

2. Leech measurement is taken in a straight line from head measuring point to clew measuring point.
3. 7 full length battens only.
4. There is no restriction on batten material.
5. The bottom batten position is restricted. The dimensions restricting the location are measured to the inside edge of the stitching that forms the bottom of the batten pocket.
6. Leech profile shall be a fair curve.
7. Leech cord can be internal, external or non-existent.
8. Leech cords shall be adjustable on the sail or boom only, and control line tails not lead to another place.
9. Sail Numbers shall be positioned in accordance with ISAF rules.
10. Reef points may be fitted if desirable.
11. The sail measurement dimensions are as per the following table and the drawing.

Sail measurement position	Dimensions	
	Maximum	Minimum
Luff	6,096mm	
Leech	6,325mm	
Top width	125mm	
Upper leech point	762mm	
Upper width	570mm	
Three quarter width	1,080mm	
Half width	1,695mm	
Quarter width	2,030mm	
Foot	2,134mm	
Tack point to bottom batten @ luff		356mm
Clew point to bottom batten @ Leech		270mm
Tack reef point		750mm up luff
Clew reef point		800mm up leech

11-RACING

1. The craft may be raced single-handed or with a crew but the number must remain constant throughout any sanctioned event.
2. Boats shall comply with the safety regulations of the National Yachting Authority of their own country.
3. At sanctioned events, only in the event of major damage can a mast, a sail, a hull assembly, a single hull, a main beam or a rear beam be changed and such change shall have the approval of the sailing committee.
4. Only fully paid members of the Paper Tiger Association shall be eligible to race in sanctioned events.

12-THE FOLLOWING ARE PROHIBITED

1. Any device for adjustment of the bend in the mast while racing except for lower forestay, mainsheet system, downhaul and boom vang.
2. Trapeze or sliding seat.
3. Pocket luff or loose foot sails.
4. Curved travellers
5. Fairing of streamlining of beams or masts.
6. Downhaul adjustment using drum winches, geared winches or levers.
7. Any device for altering batten tensions, excluding leech cords, while racing.
8. Electronic or mechanical devices for measuring speed of wind or yacht.

13-AMENDMENTS

1. Amendments to these Rules shall be by at least two thirds majority of all ballot papers returned by financial Paper Tiger Catamaran Association members.
2. A ballot paper may be handed out or sent by mail, fax or electronic media to all members. Only one vote per member shall be returned in the allowed time.
3. A ballot paper must contain at least two arguments for and against the proposed change.
4. A maximum of sixty days from date of posting the ballot paper must be allowed for return mail.
5. All ballot papers must first be reviewed and approved by all national measurers before being sent to members.
6. Any approved rule change shall apply from the first day of the next July or such date as may be determined by the World Council.
7. This By-Law comes into force on the 1st of November 1999.